

THIS DRAWING IS UNPUBLISHED. RELEASED FOR PUBLICATION, 19 .
 © COPYRIGHT 19 BY AMP INCORPORATED. ALL INTERNATIONAL RIGHTS RESERVED.

LOC	DIST	P	F	REVISIONS				
				ZONE	LTR	DESCRIPTION	DATE	APPD
AF	50				R	ADDED -3 PER OG3A-0052-99	20JUL99	JR/KR

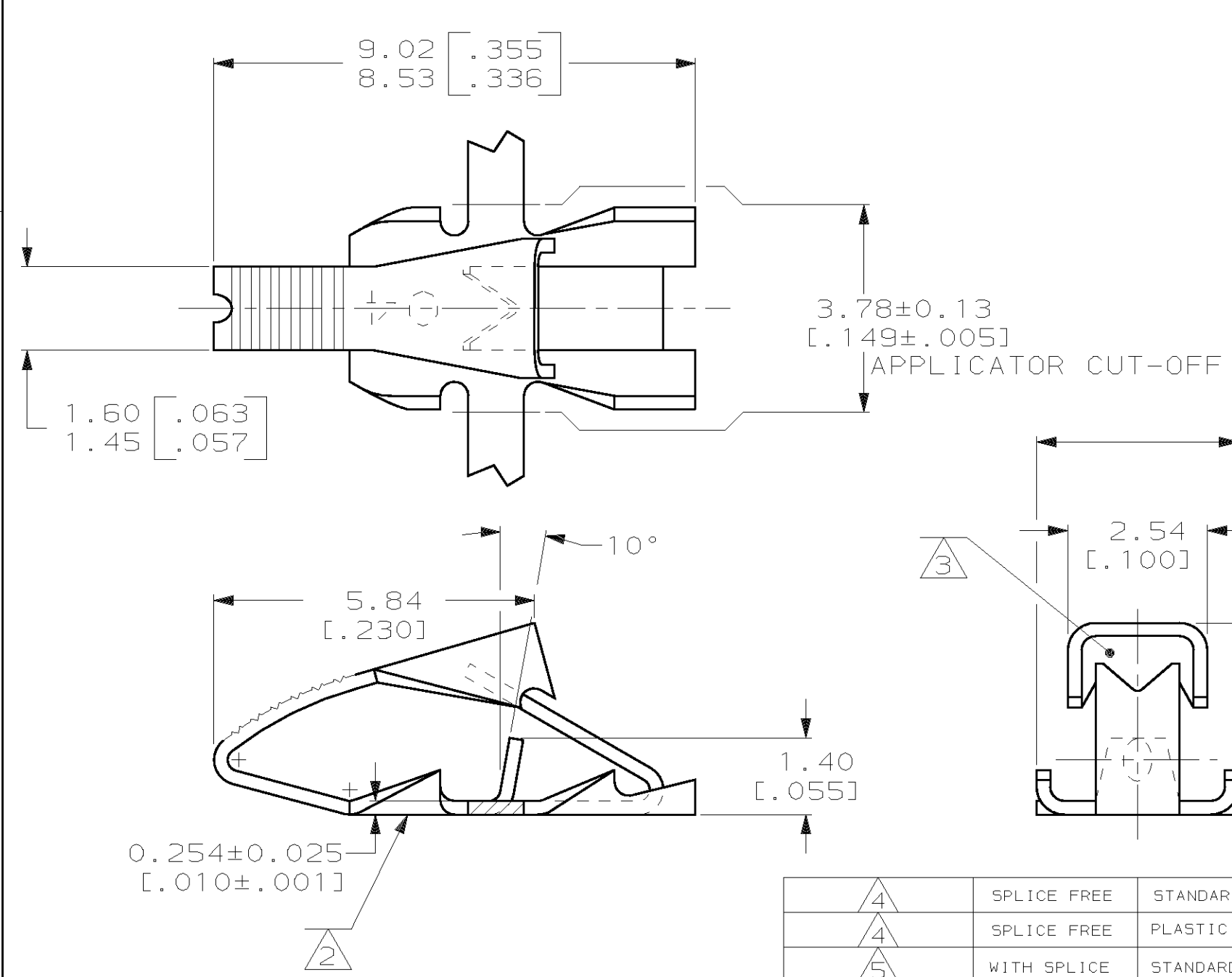

- 1 CONTINUOUS STRIP ON REELS WITH TERMINALS LOCATED ON 6.10±0.08 [.240±.003] CENTERS.
- 2 IDENTIFICATION NUMBER (04) FOR MAGNET WIRE RANGE.
- 3 SOLID OR FUSED STRANDED LEAD WIRE 0.3-0.9mm² [#22-#18] AWG.
- 4 0.001016 [.000040] MIN TIN.
- 5 0.002032 [.000080] MIN TIN.

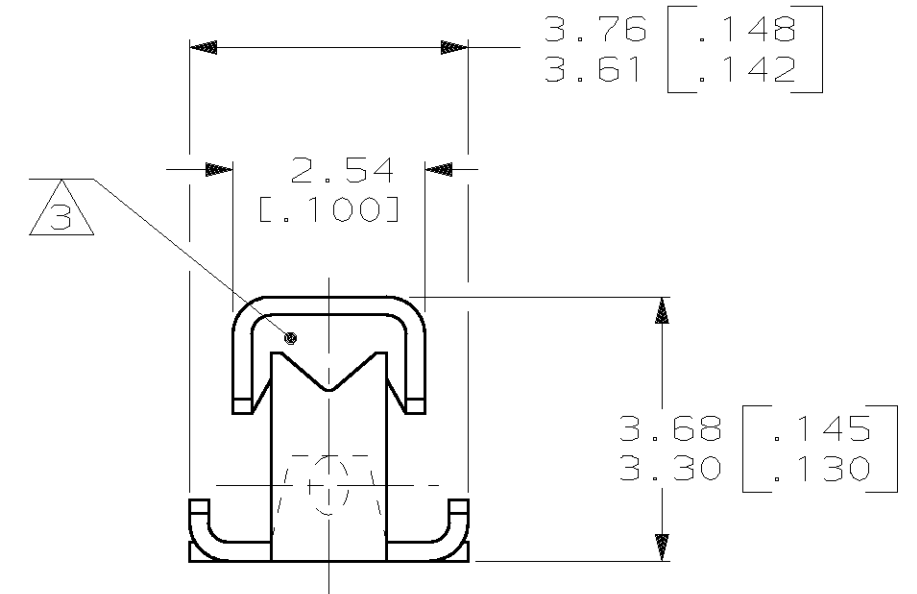

4	SPLICE FREE	STANDARD REELS	0.02-0.06mm [#52-#42] AWG	62781-3
4	SPLICE FREE	PLASTIC REELS	0.02-0.06mm [#52-#42] AWG	62781-2
5	WITH SPLICE	STANDARD REELS	0.02-0.06mm [#52-#42] AWG	62781-1
FINISH	SPLICE	REELING	COPPER MAGNET WIRE RANGE	PART NUMBER



DO NOT SCALE PRINT. UNLESS SPECIFIED DIMENSIONS IN mm [INCHES] TOLERANCES ON:
 2 PLC DEC ± -
 3 PLC DEC ± 0.25 [.010]
 ANGLES ± -

MATERIAL
 H02 HARD BRASS

FINISH
 SEE TABLE

DR 9/27/89
 MICHAEL S. FEHER

CHK 10/12/89
 JEFF R. RUTH

APPD 10/12/89
 NELSON E. NEFF

APPD 10/12/89
 TERRY L. SHUTTER

PRODUCT SPEC
 108-2016

APPLICATION SPEC
 114-2047

WEIGHT -

AMP AMP INCORPORATED
 Harrisburg, Pa. 17105

NAME
 TERMINAL, POKE-IN,
 MINI MAG-MATE™

SIZE B	CAGE CODE 00779	DRAWING NO 62781
SCALE 10:1	SHEET 1 OF 1	